

EXOTHERMIC

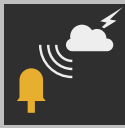

WELDING

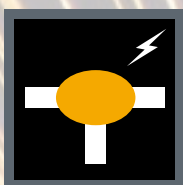

> APLIWELD® Secure+, the exothermic welding system	146
> Exothermic welding in tablets	146
> Innovation, less stock costs and more safety	148
> This is how the new components are used	149
> APLIWELD® Secure+	150
> Graphite moulds	151
> Accessories	152
> Clamps, cleaning tools, conductor fittings and others	152
> APLIWELD® Secure+ railway applications	154
> Clamps, cleaning tools, conductor fittings and others	155
> Reference selection guide	156
> Reference selection table: Suitable moulds, tablets and clamps	158
> Multiple mould selection guide	168
> APLIWELD® Secure+ reference list	169



> APLIWELD® SECURE+ EXOTHERMIC WELDING SYSTEM

> EXOTHERMIC WELDING IN TABLETS

APLIWELD® Secure+ replaces the traditional welding powders and their manual spark activation with a tablet compound shape activated remotely using an electronic starter.



> **APLIWELD®-T**
Welding compounds in tablets

> **APLIWELD®-E**
Electronic starters for exothermic welding

> **KIT APLIWELD®-E**
Electronic starting device



REDUCES OCCUPATIONAL HAZARDS

- > Remote ignition control
- > Non-flammable materials involved



SAVES ON COST

- > No package size limitations
- > Simplifies transport and storage conditions
- > Reduces workforce and training



SIMPLIFIES WORK

- > Easy to use
- > Enables work to continue in windy or humid conditions
- > Reduces waste

> APLIWELD® SECURE+ EXOTHERMIC WELDING SYSTEM

> EXOTHERMIC WELDING IN TABLETS

> CERTIFICATIONS



Certification in agreement with UL467 Grounding and bonding equipment

Underwriters Laboratories is a global recognised safety science company which certifies, validates and tests a wide range of products. In electrical connections, and particularly for exothermic welding, UL467 standard "Grounding and bonding equipment" is the reference for the quality and reliability in connections between electric conductors. Connections are subject to a current test and a stringent mechanical test, involving two parts: a secureness and pull-out assays.

Apliweld has achieved this UL certification for the cable/cable, cable/earth rod, cable/metal surface and tape/tape connections appearing in this catalogue and validated in UL installations. Also 50 mm²

cable and cross shape rebar, 30 x 2 mm tape to T-shape earth rod and all 50 mm² cable to 30 x 2 mm tape connections are certified.

Explosive atmosphere certificate:

The Apliweld compound has shown zero flammability, passing the explosive atmosphere test in Laboratorio Oficial Madariaga (LOM). In this assay, explosive limits, minimum flammability energy and temperature, as well as parameters such as pressure and product explosive limits are tested under the applicable UNE standards. The sample turned out to be inert during testing and was classified as St0, or non-explosive/non-flammable.



Other certifications

Apliweld Secure+ has passed short-current tests supervised by the Technological Institute of Energy (ITE) in Spain, demonstrating even better conductivity than the conductors themselves.

> REGULATIONS

Compliance with NTP 1028 safety in copper aluminothermic welding.

"The electronic ignition method is the most suitable for aluminothermic welding, as it encompasses significant improvements in safety in relation to any other method"

Compliance with ITC-BT-26 internal housing installations. General installation requirements.

"Earthings: [...] if applicable, the metal structure of the building will be connected to the annealed conductor, or the electrodes, or when the foundation of the structure is built using reinforced concrete footings, a certain number of irons of those considered most important and a minimum of one per footing. Those connections will be made in a safe and reliable way using aluminothermic or autogenous welding methods"



WITH ALL THE BENEFITS OF EXOTHERMIC WELDING

The connection has equal or higher electrical conductivity than the conductors themselves.

Welding does not degrade throughout time and is resistant to galvanic coupling.

Withstands repeated current impulses.

Resistance never increases.

Higher mechanical and crush resistance than the conductors themselves.

Apliweld® Secure+ offers a permanent welding and high-resistance connection which is essential to achieve a lasting and reliable result for any earthing.

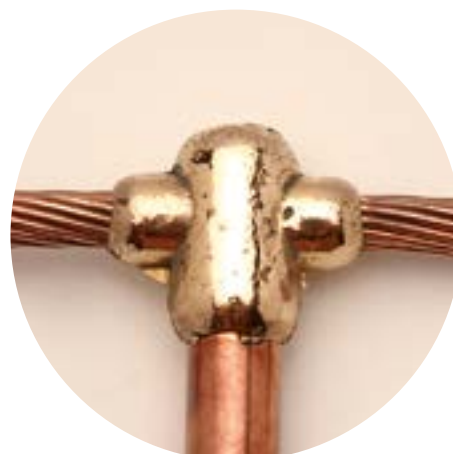



> APLIWELD® SECURE+ EXOTHERMIC WELDING SYSTEM

> INNOVATION, REDUCTION IN STORAGE COSTS AND INCREASED SAFETY

Traditionally, exothermic welding required the user to have multiple cartridges with different powder weights for carrying out the various connections. Once the conductors were inserted in the graphite mould, the welding compound and the reactive powder (usually a flammable compound) were poured into the crucible. Then a flint gun, applied manually to the starting powder at arm's length produced a spark triggering the exothermic reaction.

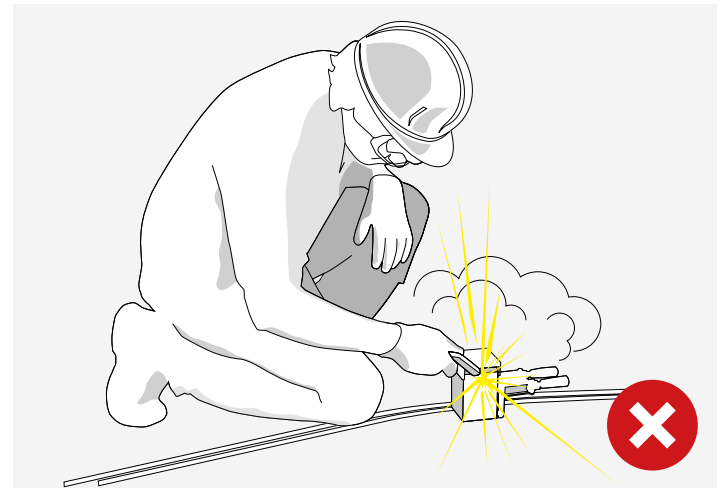

With **APLIWELD® Secure +** the required number of tablets are placed inside the graphite mould. The electronic starter is inserted on top and activated from a distance. Hence there is no need for multiple cartridges and it is completely safe for the operator.

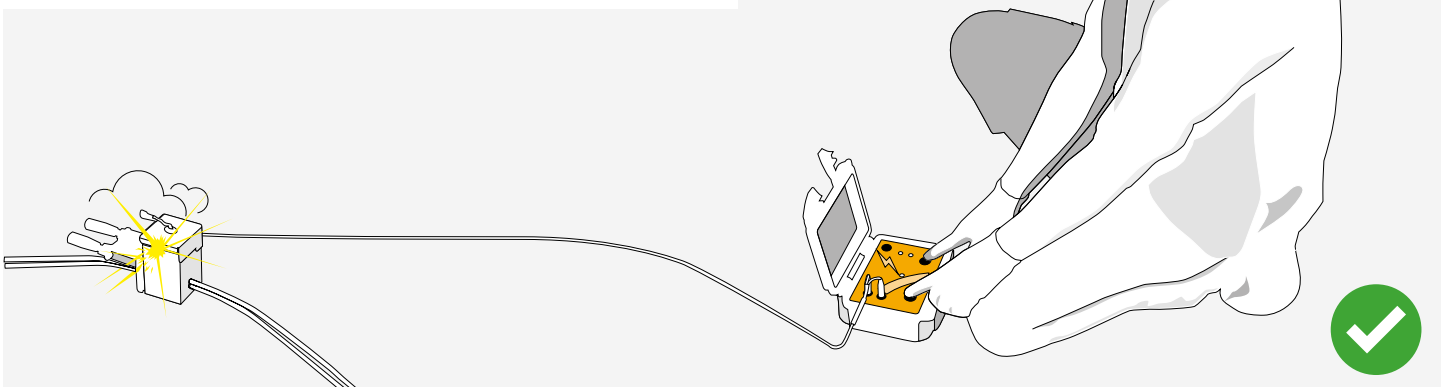
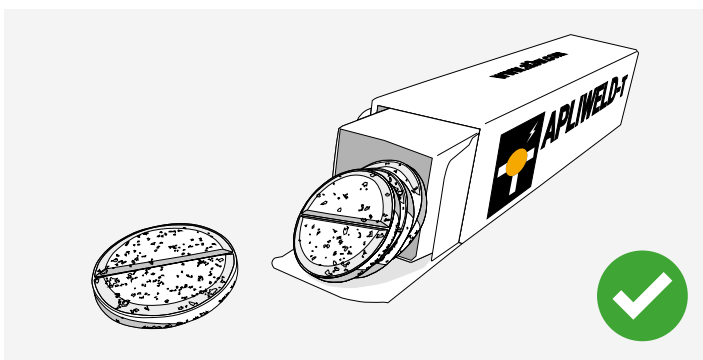

> APLIWELD® SECURE+ EXOTHERMIC WELDING SYSTEM

> THIS IS HOW THE NEW COMPONENTS ARE USED

Insert the retaining disc and the **APLIWELD®-T** tablets

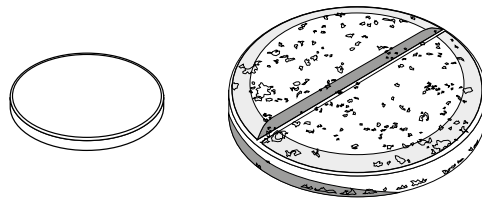

Insert and connect the electronic starter **APLIWELD®-E**

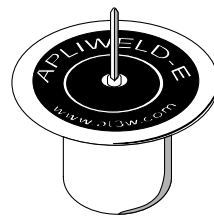

Press both buttons at the same time in **Kit APLIWELD®-E**

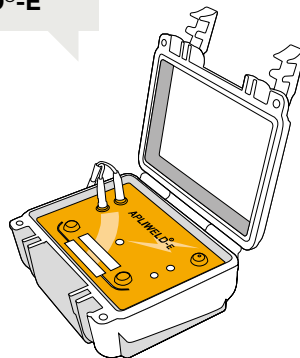

Remove the completed joint from the graphite mould

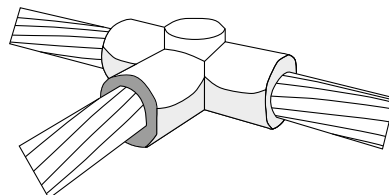



> APLIWELD® SECURE+

> APLIWELD®-T



AT-020N: tablets for exothermic welding

Innovative welding compound in tablet form for carrying out any connections using one or more tablets.

Two references: **AT-020N**, the most common one (valid for 90% of connections) and **AT-021N**, biggest tablets, suitable for welding larger conductors.

- ✓ Compact and easy to use
- ✓ Reduces stock costs
- ✓ Improves welding process times
- ✓ Increases equipment life-time
- ✓ Both electronic and powder starters can be used

> TECHNICAL CHARACTERISTICS

Reference:	AT-020N	AT-021N
Tablet dimensions:	Ø43 mm	Ø55 mm
Units per pack:	20 tablets	20 tablets
Dimensions:	52 x 52 x 220 mm	66 x 66 x 260 mm
Weight:	900 g	2,000 g

> APLIWELD®-E



AT-010N: electronic starter for exothermic welding

Non-flammable electronic starters only ignite by means of the energy they receive from the ignition device.

Includes 10 metal retaining disks for better product/slag separation.

> TECHNICAL CHARACTERISTICS

Reference:	AT-010N
Dimensions:	Ø24 mm x 26 mm
Units per pack:	10 starters
Dimensions:	125 x 105 x 40 mm
Weight:	87 g
Reaction time:	<10 seconds
Material:	non-flammable

- ✓ Its safety features in terms of handling, storage and transport reduce occupational hazards labour risks
- ✓ Safe and easy set up

> KIT APLIWELD®-E



AT-100N: ignition box

Ignition box enables controlled and remote electronic ignition in a quick and safe way. Includes: ignition unit (**AT-096N**), cable (**AT-098N**), 5 crocodile clips (**AT-099N**), battery charger and transporting bag.

> TECHNICAL CHARACTERISTICS

Reference:	AT-100N
Power supply:	Lead-acid battery 6 V 7 Ah
Operating voltage:	6 V _{DC}
Battery charge:	12-36V _{DC} 500 mA
Battery life:	more than 100 welds
Case dimensions:	216 x 180 x 102 mm
Case weight:	2,300 g
Cable dimensions:	2 x 1.5 x 1,500 mm
Total packaging weight:	3,500 g
Work temperature:	-10°C to 60°C

- ✓ Enables remote electronic ignition thereby reducing occupational hazards

> GRAPHITE MOULDS

> SPECIFIC MOULDS

Each mould makes a particular connection: one mould welds two specific conductors (cable to cable, tape to tape, cable to earth rod...), with specific dimensions (50 mm², 70 mm² etc.) and joined in a certain way (cross or T shape etc.).

> TECHNICAL CHARACTERISTICS

- > Each mould can carry out around 50-100 welds, depending on the model.
- > Consult all references, accessories and required tablets in this guide (reference selection on pages 156-169) or use the “specific mould selection” on our website.
- > The welding manual explains the procedures for correctly using specific moulds. **APLIWELD®** (download it at www.at3w.com).
- > All specific moulds are adapted for both the electronic starter (**APLIWELD-E®**) and starting powder (**AT-012N**) ignition types.



> MULTIPLE MOULD

The multiple mould is a system designed to make different connections using the same graphite pieces (see multiple mould selection guide on page 168).

> TECHNICAL CHARACTERISTICS

- > Multiple mould is focused for horizontal T, cross and earth rod welding. However, in some cases it can also weld straight and parallel bonds. It welds cables up to 95 mm², tapes up to 30 mm wide and earth rods up to 19 mm in diameter.
- > The product is supplied in a case that contains all the necessary materials to carry out the welding, except for the consumables (see page 168).
- > The **MM-CS** cavity sealants are, along with the tablets, the consumables involved in the process. MM-CS are supplied in packets of 60 units. They form the welding cavity and are placed according to the table of connections (see page 168).
- > Graphite moulds can withstand at least 80 welds.
- > The multiple mould is the best solution if only a few common welding types are required, when the features of the work to be carried out cannot be predicted, when conductor sizes are variable or in case of any unexpected occurrences during installation.
- > Read the instructions provided with all multiple mould cases or download the **APLIWELD®** manual at www.at3w.com.
- > It is adapted for both electronic starter (**APLIWELD-E®**) and starting powder (**AT-012N**) ignition types.





> ACCESSORIES

> CLAMPS, CLEANING TOOLS, CONDUCTOR FITTINGS AND OTHERS

> BASIC ACCESSORIES KIT



AT-068N

AT-069N is a cleaning tool set for conductors and moulds. It includes safety gloves and sealing paste.

The **AT-068N** tool set involves the same references as the one described but also includes a spark lighter, (**AT-060N**) essential for traditional starting powder ignition.

> TECHNICAL CHARACTERISTICS

AT-069N	Reference	Description
Includes:	AT-061N	Conductor cleaning brush
	AT-062N	Crucible and electronic starter cavity cleaning brush
	AT-063N	Slag scraper
	AT-064N	Welding cavity cleaning brush
	AT-065N	Sealing paste (0.45 kg)
	AT-073N	Safety gloves
Dimensions:	250 x 125 x 140 mm	
Weight:	1,000 g	

It is advisable to have a new set for every 250 welds

> GENERAL CLAMP TYPE S



AT-049N

Accessory to facilitate safe fastening, closing and handling of the moulds it is to be used with. This is the most common clamp, suitable for approximately 80% of connections. For connections to a metal surface (HT and HP type), **AT-058N** tool should be used together with the clamp **AT-049N** to avoid loss of material.

> TECHNICAL CHARACTERISTICS

Reference	AT-049N
Dimensions:	65 x 65 x 250 mm
Weight:	1,250 g
Service life:	Approx. 250 welds

> GENERAL CLAMP TYPE G



AT-050N

Accessory similar to **AT-049N** but bigger. Valid for large conductors and some particular welds such as LO, XO, TO types.

For connections to a metal surface (HT and HP type), **AT-058N** tool should be used together with the clamp **AT-050N** to avoid loss of material.

> TECHNICAL CHARACTERISTICS

Reference	AT-050N
Dimensions:	80 x 80 x 275 mm
Weight:	1,470 g
Service life:	Approx. 250 welds

> ACCESSORIES

> CLAMPS, CLEANING TOOLS, CONDUCTOR FITTINGS AND OTHERS

> OTHER CLAMPS AND ACCESSORIES

Beside the described products, other accessories are required for less common connections or to ensure good quality welding according to working conditions. Find all the references on page 169. The most common accessories are described next:



AT-065N: Sealing paste (0.45 kg). **AT-066N** (0.9 kg) and **AT-071N** (2.25 kg) also available.



MM-053N: Multiple mould clamp.



AT-051N: Clamp for vertical metal surface splices or along vertical rebars or earth rods.



AT-077N: Safety goggles: Recommended for all works.



AT-059N: Cable-holder clamp to prevent conductors from separating during the welding reaction. Complements **AT-049N** or **AT-050N** in any connection involving a through cable.



AT-072NCXX: Copper adapter sleeves with variable diameters depending on XX selection. XX indicates the mm² of the desired cable. They increase the conductor diameter fitting it in a mould designed for bigger cables. X=50, 70, 120...



> APLIWELD® SECURE+ RAILWAY APPLICATIONS

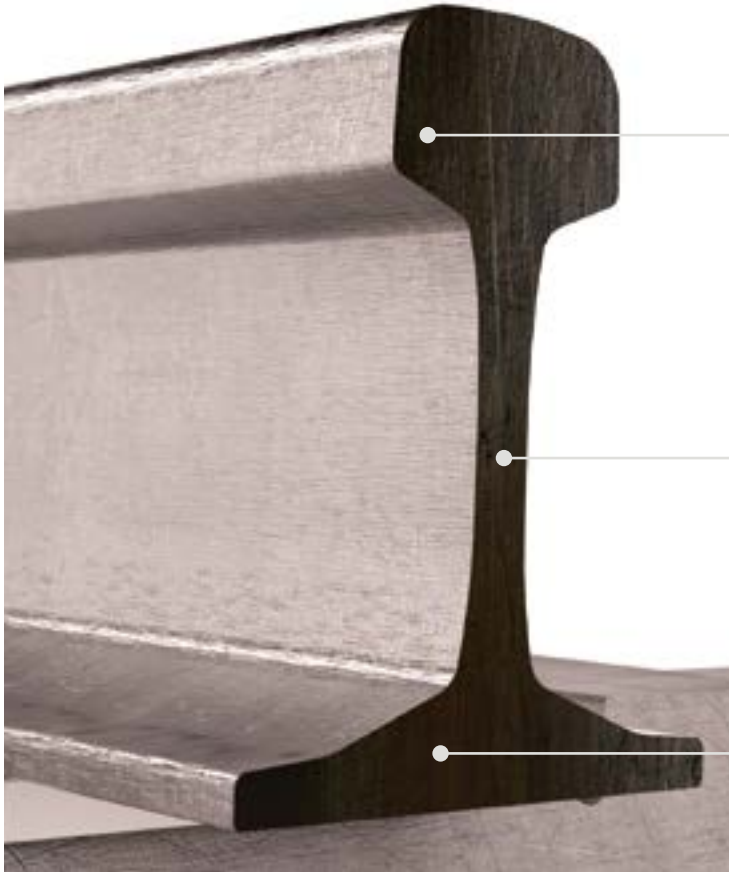

HEAD

Rail-head connections are usually intended to electrically connect two track sections, which are normally mechanically bonded. Welding must be done within the area marked by the splice bar. **Graphite moulds** and suitable clamps are used for cable to rail-head welds.

WEB

Besides the applications in rail to head connections, cable to web joints are also used to carry the return current to the substation or to balance this current on both sides of the railway on its way back. The utmost care must be taken to carry out the welding in the middle of the web, thereby preventing any damage to the rail. **Graphite moulds** and suitable clamps are used for cable to rail-head welds.

FOOT

The rail foot is usually the most sensitive part to carry out welding, but at the same time it is the most convenient and fastest part. Specific single-use sand moulds are used, including the corresponding railsleeve. Fastening clamps are not required.

The appropriate tools should be selected in order to carry out rail welding. Use the tables on page 167 to assign the proper mould, tablets and clamp required depending on where the welding is to be carried out (head-web-foot), the size of the conductor to be welded (35-50-95... mm²) and if it goes all the way through or has an end point.

However, it is also important to establish the **rail profile** given that each rail varies in size and perhaps the same mould could work in a certain part of the rail and conductor for one rail but not for another.

In the following table you can find some examples of rail profiles, within a wide range of types, dimensions and shapes.

> TYPES OF RAIL

Standard	Type of rail	Dimensions (mm)				
		A	B	C	D	E
European	UIC54	70	49.4	159	140	16
European	UIC54E	67	51.4	161	125	16
European	UIC60	72	51	172	150	16.5
Chinese	CHINA 50	70	42	152	132	15
USA	ASCEP5	65.1	39.3	131.8	130.2	14.3

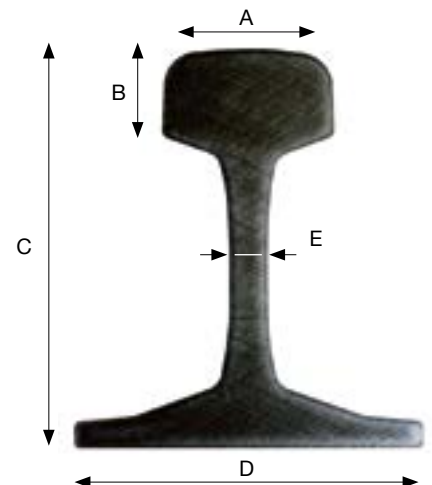

> APLIWELD® SECURE+ RAILWAY APPLICATIONS

> CLAMPS, CLEANING TOOLS, CONDUCTOR FITTINGS AND OTHERS



> CLAMPS



AT-054N



AT-056N



AT-057N

Fastening, closing and handling clamp accessories for rail head, web and foot mould.

> TECHNICAL CHARACTERISTICS

Reference	AT-054N	AT-056N	AT-057N
Type of welding:	Cable clamp/Rail web	Cable clamp/Rail head	Cable clamp/Rail head according to E.T. 03.364.005.3, ADIF or similar
Dimensions:	65 x 65 x 250 mm	80 x 80 x 275 mm	80 x 80 x 275 mm
Weight:	1,250 g	950 g	1,470 g
Service life:	Approx. 120 welds	Approx. 120 welds	Approx. 120 welds

> HAMMER-DIE AND RAIL SLEEVES



Hammer-die

Railsleeve

In order to ensure the connection is secure and to prevent material leakages, it is advisable (when not compulsory) to make use of the hammer-die corresponding to the rail sleeve at the end of the conductor to be welded:

To weld with:	Adapter sleeve ref:	Hammer-die
35 mm ² cable	AT-SC35	AT-M035N
50 mm ² cable	AT-SC50	AT-M050N
70 mm ² cable	AT-SC70	AT-M070N
95 mm ² cable	AT-SC95	AT-M095N
120 mm ² cable	AT-SC120	AT-M120N
150 mm ² cable	AT-SC150	AT-M150N
185 mm ² cable	AT-SC185	AT-M185N



> REFERENCE SELECTION GUIDE

1

The following diagram shows you how to select the correct **APLIWELD®** products for each welding using the reference selection tables on pages 158-169.

a Find the required connections and conductors

b Mould reference

c Tablet reference and no. of tablets per connection

d Corresponding clamp reference

1 Connection	Reference	Conductor 1	Conductor 2	Tab Ref.	Tab/Conn.	Clamp
	C35/C35/LV	35 mm ² cable	35 mm ² cable	AT-020N	1	AT-049N
	C50/C50/LV	50 mm ² cable	50 mm ² cable	AT-020N	1	AT-049N
	C70/C70/LV	70 mm ² cable	70 mm ² cable	AT-020N	1.5	AT-049N
	C95/C95/LV	95 mm ² cable	95 mm ² cable	AT-020N	2	AT-049N
	C120/C120/LV	120 mm ² cable	120 mm ² cable	AT-020N	2	AT-049N
	C150/C150/LV	150 mm ² cable	150 mm ² cable	AT-020N	2.5	AT-049N

From table 1 (page 158)

2

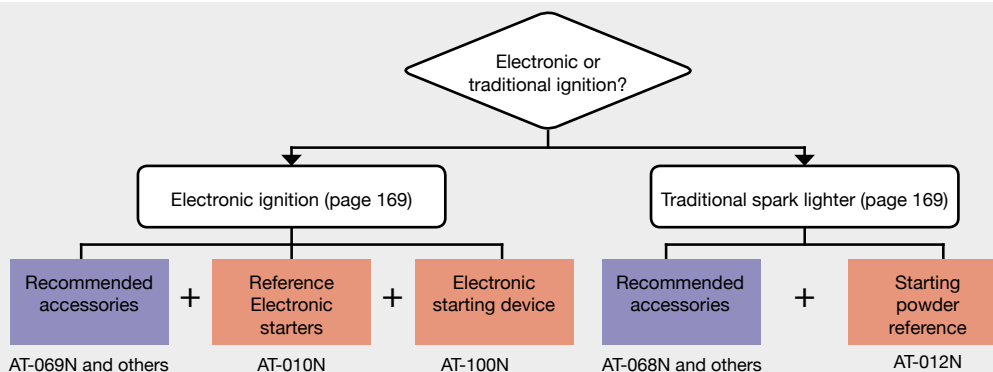

3

Set the corresponding quantities for each reference, under the following criteria:

Reference	Description	Use
Mould references	Specific or multiple	50 - 100 welds per mould
AT-020N	Welding compounds in tablets	20 tablets per box
AT-021N	Welding compounds in tablets	20 tablets per box
AT-010N	Electronic starters for exothermic welding	10 electronic starters per box
AT-012N	Exothermic welding starting powder	10 starters in powder per box
AT-049N	General clamp type S	250 connections per clamp
AT-050N	General clamp type G	250 connections per clamp
AT-068N	Basic accessories kit	250 welds per basic accessories kit
AT-100N	Electronic starting device	10 years use of electronic ignition device

> In order to determine the number of other accessories needed, please consult our technical department.

> Note that quantities may change depending on the working conditions (if there is more than one installer, more than one working place or any particular harsh conditions).

> Download the Welding Manual **APLIWELD®** for further information regarding the products and how to use them. Find answers to the most common **APLIWELD®** welding issues.

Please contact us if you have any questions.

> REFERENCE SELECTION GUIDE

> SELECTION EXAMPLE 1:

An installer should carry out 300 horizontal T type welds, between two cables of 50 mm² using the electronic ignition system.

Then please use as follows:

1

a Find the required connections and conductors

b Mould reference

c Tablet reference and no. of tablets per connection

d Corresponding clamp reference

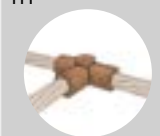
2	Connection	Reference	Conductor 1	Conductor 2	Tab Ref.	Tab/Conn.	Clamp
	TH	C35/C35/TH	35 mm ² cable	35 mm ² cable	AT-020N	1.5	AT-049N
		C50/C50/TH	50 mm² cable	50 mm² cable	AT-020N	2	AT-049N
		C70/C70/TH	70 mm ² cable	70 mm ² cable	AT-020N	2	AT-049N
		C95/C95/TH	95 mm ² cable	95 mm ² cable	AT-020N	2.5	AT-049N
		C120/C120/TH	120 mm ² cable	120 mm ² cable	AT-020N	3	AT-049N

From table 2 (page 158)

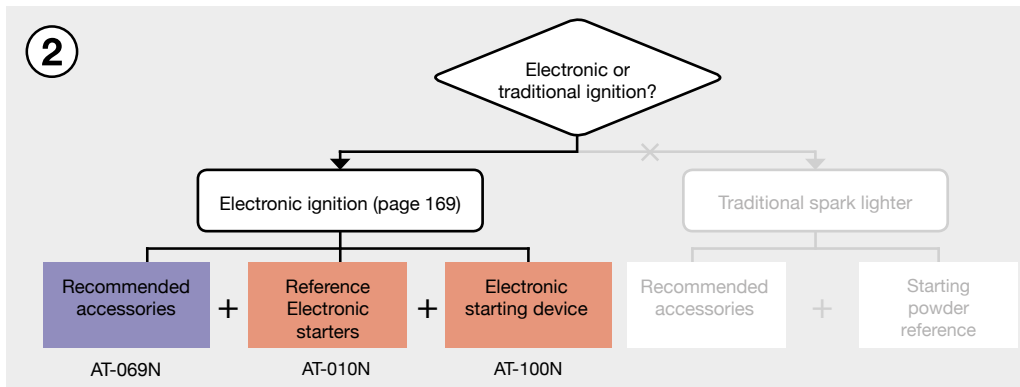

3

With the data and the references obtained, the order could be as follows:

Reference	Units
C50/C50/TH	4
AT-020N	30
AT-010N	30
AT-049N	2
AT-069N	2
AT-100N	1

> SELECTION EXAMPLE 2:

Two working groups should carry out 450 welds between 120 mm² cables in a horizontal cross shape using traditional spark lighter ignition.

1

a Find the required connections and conductors

b Mould reference

c Tablet reference and no. of tablets per connection

d Corresponding clamp reference

3	Connection	Reference	Conductor 1	Conductor 2	Tab Ref.	Tab/Conn.	Clamp
	XH	C35/C35/XH	35 mm ² cable	35 mm ² cable	AT-020N	2	AT-049N
		C50/C50/XH	50 mm ² cable	50 mm ² cable	AT-020N	2	AT-049N
		C70/C70/XH	70 mm ² cable	70 mm ² cable	AT-020N	2.5	AT-049N
		C95/C95/XH	95 mm ² cable	95 mm ² cable	AT-020N	3	AT-049N
		C120/C120/XH	120 mm² cable	120 mm² cable	AT-020N	4.5	AT-049N

From table 3 (page 159)

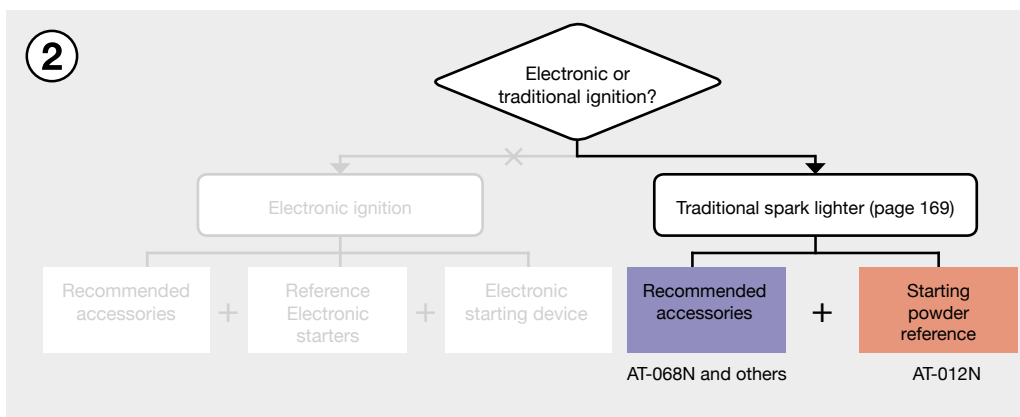

3

With the data and the references obtained, the order could be as follows:

Reference	Units
C120/C120/XH	9
AT-020N	102
AT-012N	45
AT-049N	2
AT-068N	4
AT-100N	NA



> REFERENCE SELECTION TABLE: SUITABLE MOULDS, TABLETS AND CLAMPS

Connection:
Drawing and union type code.
In tables where more than one connection appears, the correct mould reference is obtained by replacing the letters of the union type with those of the connection required.

Reference: Conductor 1/Conductor 2/Union type.
Conductor 1: Code of conductor to be welded.
If conductors from different sections are welded, then Conductor 1 will be the run conductor.
Conductor 2: Code of conductor to be welded.
If conductors from different sections are welded, then Conductor 2 will be the tap conductor.

Tab ref.: Tablet size reference.
Tab/con: Tablets required per connection.

Clamp: Reference of accessory needed for a tight lock and safe handling of the mould.
Notes: Warnings and recommended accessories.

For e.g.: If a vertical T mould for 240 mm² cables is required, just replace C240/C240/TH with C240/C240/TV. The number of tablets and other accessories will remain the same.

2	Connection	Reference	Conductor 1	Conductor 2	Tab Ref.	Tab/Conn.	Clamp	Notes
TH		C35/C35/TH	35 mm ² cable	35 mm ² cable	AT-020N	1.5	AT-049N	
		C50/C35/TH	50 mm ² cable	35 mm ² cable	AT-020N	1.5	AT-049N	
		C70/C70/TH	70 mm ² cable	70 mm ² cable	AT-020N	2	AT-049N	
		C95/C95/TH	95 mm ² cable	95 mm ² cable	AT-020N	2.5	AT-049N	
TV		C120/C120/TH	120 mm ² cable	120 mm ² cable	AT-020N	3	AT-049N	
		C150/C150/TH	150 mm ² cable	150 mm ² cable	AT-020N	4	AT-049N	
		C185/C185/TH	185 mm ² cable	185 mm ² cable	AT-021N	2	AT-050N	
		C240/C240/TV	240 mm ² cable	240 mm ² cable	AT-021N	3	AT-050N	
		C50/C35/TH	50 mm ² cable	35 mm ² cable	AT-020N	1.5	AT-049N	
		C70/C35/TH	70 mm ² cable	35 mm ² cable	AT-020N	1.5	AT-049N	



COMMON CONNECTIONS:

Cable/Cable:	Tables 1-5	Cable/Metal surface:	Tables 14-15	Tape/Earth rod:	Table 21
Cable/Earth rod:	Tables 6-8	Tape/Tape:	Tables 16-18	Others:	Table 22
Cable/Rebar:	Tables 9-13	Cable/tape:	Tables 19-20	Railroad:	Tables 23-28
				Multiple mould: :	Tables 29-30

> CABLE/CABLE

1	Connection	Reference	Conductor 1	Conductor 2	Tab Ref.	Tab/Conn.	Clamp	Notes
LV		C35/C35/LV	35 mm ² cable	35 mm ² cable	AT-020N	1	AT-049N	
		C50/C50/LV	50 mm ² cable	50 mm ² cable	AT-020N	1	AT-049N	
		C70/C70/LV	70 mm ² cable	70 mm ² cable	AT-020N	1.5	AT-049N	
		C95/C95/LV	95 mm ² cable	95 mm ² cable	AT-020N	2	AT-049N	
		C120/C120/LV	120 mm ² cable	120 mm ² cable	AT-020N	2	AT-049N	
		C150/C150/LV	150 mm ² cable	150 mm ² cable	AT-020N	2.5	AT-049N	
		C185/C185/LV	185 mm ² cable	185 mm ² cable	AT-021N	2	AT-050N	
		C240/C240/LV	240 mm ² cable	240 mm ² cable	AT-021N	2	AT-050N	

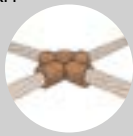
2	Connection	Reference	Conductor 1	Conductor 2	Tab Ref.	Tab/Conn.	Clamp	Notes
TH		C35/C35/TH	35 mm ² cable	35 mm ² cable	AT-020N	1.5	AT-049N	
		C50/C35/TH	50 mm ² cable	35 mm ² cable	AT-020N	1.5	AT-049N	
		C50/C50/TH	50 mm ² cable	50 mm ² cable	AT-020N	2	AT-049N	
		C70/C35/TH	70 mm ² cable	35 mm ² cable	AT-020N	1.5	AT-049N	
TV		C70/C50/TH	70 mm ² cable	50 mm ² cable	AT-020N	2	AT-049N	
		C70/C70/TH	70 mm ² cable	70 mm ² cable	AT-020N	2	AT-049N	
		C95/C35/TH	95 mm ² cable	35 mm ² cable	AT-020N	2	AT-049N	
		C95/C50/TH	95 mm ² cable	50 mm ² cable	AT-020N	2	AT-049N	
		C95/C70/TH	95 mm ² cable	70 mm ² cable	AT-020N	2.5	AT-049N	
		C95/C95/TH	95 mm ² cable	95 mm ² cable	AT-020N	2.5	AT-049N	
		C120/C35/TH	120 mm ² cable	35 mm ² cable	AT-020N	2	AT-049N	
		C120/C50/TH	120 mm ² cable	50 mm ² cable	AT-020N	2.5	AT-049N	
		C120/C70/TH	120 mm ² cable	70 mm ² cable	AT-020N	2.5	AT-049N	
		C120/C95/TH	120 mm ² cable	95 mm ² cable	AT-020N	3	AT-049N	
		C120/C120/TH	120 mm ² cable	120 mm ² cable	AT-020N	3	AT-049N	
		C150/C35/TH	150 mm ² cable	35 mm ² cable	AT-020N	2.5	AT-049N	
		C150/C50/TH	150 mm ² cable	50 mm ² cable	AT-020N	2.5	AT-049N	
		C150/C70/TH	150 mm ² cable	70 mm ² cable	AT-020N	3	AT-049N	
		C150/C95/TH	150 mm ² cable	95 mm ² cable	AT-020N	3	AT-049N	
		C150/C120/TH	150 mm ² cable	120 mm ² cable	AT-020N	3.5	AT-049N	
C150/C150/TH	150 mm ² cable	150 mm ² cable	AT-020N	4	AT-049N			
C185/C185/TH	185 mm ² cable	185 mm ² cable	AT-021N	2	AT-050N			
C240/C240/TH	240 mm ² cable	240 mm ² cable	AT-021N	3	AT-050N			

3	Connection	Reference	Conductor 1	Conductor 2	Tab Ref.	Tab/Conn.	Clamp	Notes
	XH	C35/C35/XH	35 mm ² cable	35 mm ² cable	AT-020N	2	AT-049N	
		C50/C35/XH	50 mm ² cable	35 mm ² cable	AT-020N	2	AT-049N	
		C50/C50/XH	50 mm ² cable	50 mm ² cable	AT-020N	2	AT-049N	
		C70/C35/XH	70 mm ² cable	35 mm ² cable	AT-020N	2	AT-049N	
		C70/C50/XH	70 mm ² cable	50 mm ² cable	AT-020N	2	AT-049N	
	PH	C70/C70/XH	70 mm ² cable	70 mm ² cable	AT-020N	2.5	AT-049N	
		C95/C35/XH	95 mm ² cable	35 mm ² cable	AT-020N	2.5	AT-049N	
		C95/C50/XH	95 mm ² cable	50 mm ² cable	AT-020N	2.5	AT-049N	
		C95/C70/XH	95 mm ² cable	70 mm ² cable	AT-020N	3	AT-049N	
		C95/C95/XH	95 mm ² cable	95 mm ² cable	AT-020N	3	AT-049N	
		C120/C35/XH	120 mm ² cable	35 mm ² cable	AT-020N	2.5	AT-049N	
		C120/C50/XH	120 mm ² cable	50 mm ² cable	AT-020N	3	AT-049N	
		C120/C70/XH	120 mm ² cable	70 mm ² cable	AT-020N	3.5	AT-049N	
		C120/C95/XH	120 mm ² cable	95 mm ² cable	AT-020N	4	AT-049N	
		C120/C120/XH	120 mm ² cable	120 mm ² cable	AT-020N	4.5	AT-049N	
		C150/C35/XH	150 mm ² cable	35 mm ² cable	AT-020N	3	AT-049N	
		C150/C50/XH	150 mm ² cable	50 mm ² cable	AT-020N	3.5	AT-049N	
		C150/C70/XH	150 mm ² cable	70 mm ² cable	AT-020N	3.5	AT-049N	
		C150/C95/XH	150 mm ² cable	95 mm ² cable	AT-020N	4.5	AT-049N	
		C150/C120/XH	150 mm ² cable	120 mm ² cable	AT-020N	4.5	AT-049N	
		C150/C150/XH	150 mm ² cable	150 mm ² cable	AT-020N	4.5	AT-049N	
		C185/C185/XH	185 mm ² cable	185 mm ² cable	AT-021N	3	AT-050N	
C240/C240/XH	240 mm ² cable	240 mm ² cable	AT-021N	4	AT-050N			

4	Connection	Reference	Conductor 1	Conductor 2	Tab Ref.	Tab/Conn.	Clamp	Notes
	PV	C35/C35/PV	35 mm ² cable	35 mm ² cable	AT-020N	2	AT-049N	
		C50/C50/PV	50 mm ² cable	50 mm ² cable	AT-020N	2	AT-049N	
		C70/C70/PV	70 mm ² cable	70 mm ² cable	AT-020N	2.5	AT-049N	
		C95/C95/PV	95 mm ² cable	95 mm ² cable	AT-020N	3.5	AT-049N	
		C120/C120/PV	120 mm ² cable	120 mm ² cable	AT-020N	4,5	AT-049N	
		C150/C150/PV	150 mm ² cable	150 mm ² cable	AT-020N	5	AT-049N	
		C185/C185/PV	185 mm ² cable	185 mm ² cable	AT-021N	3	AT-050N	
		C240/C240/PV	240 mm ² cable	240 mm ² cable	AT-021N	4	AT-050N	

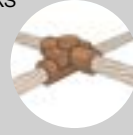
5	Connection	Reference	Conductor 1	Conductor 2	Tab Ref.	Tab/Conn.	Clamp	Notes
	XS	C35/C35/XS	35 mm ² cable	35 mm ² cable	AT-020N	2.5	AT-049N	
		C50/C35/XS	50 mm ² cable	35 mm ² cable	AT-020N	3	AT-049N	
		C50/C50/XS	50 mm ² cable	50 mm ² cable	AT-020N	3	AT-049N	
		C70/C35/XS	70 mm ² cable	35 mm ² cable	AT-020N	3	AT-049N	
		C70/C50/XS	70 mm ² cable	50 mm ² cable	AT-020N	3.5	AT-049N	
		C70/C70/XS	70 mm ² cable	70 mm ² cable	AT-020N	4	AT-049N	
		C95/C35/XS	95 mm ² cable	35 mm ² cable	AT-020N	3,5	AT-049N	
		C95/C50/XS	95 mm ² cable	50 mm ² cable	AT-020N	3,5	AT-049N	
		C95/C70/XS	95 mm ² cable	70 mm ² cable	AT-020N	4	AT-049N	
		C95/C95/XS	95 mm ² cable	95 mm ² cable	AT-020N	4,5	AT-049N	
		C120/C35/XS	120 mm ² cable	35 mm ² cable	AT-020N	4	AT-049N	
		C120/C50/XS	120 mm ² cable	50 mm ² cable	AT-020N	4,5	AT-049N	
		C120/C70/XS	120 mm ² cable	70 mm ² cable	AT-020N	5	AT-049N	
		C120/C95/XS	120 mm ² cable	95 mm ² cable	AT-020N	5	AT-049N	
		C120/C120/XS	120 mm ² cable	120 mm ² cable	AT-020N	5	AT-049N	
		C150/C35/XS	150 mm ² cable	35 mm ² cable	AT-020N	4	AT-049N	
		C150/C50/XS	150 mm ² cable	50 mm ² cable	AT-020N	4,5	AT-049N	
		C150/C70/XS	150 mm ² cable	70 mm ² cable	AT-020N	5	AT-049N	
		C150/C95/XS	150 mm ² cable	95 mm ² cable	AT-020N	5	AT-049N	
		C150/C120/XS	150 mm ² cable	120 mm ² cable	AT-020N	5	AT-049N	
C150/C150/XS	150 mm ² cable	150 mm ² cable	AT-020N	5	AT-049N			
C185/C185/XS	185 mm ² cable	185 mm ² cable	AT-021N	4	AT-050N			
C240/C240/XS	240 mm ² cable	240 mm ² cable	AT-021N	5	AT-050N			



> REFERENCE SELECTION TABLE: SUITABLE MOULDS, TABLETS AND CLAMPS

> CABLE/EARTH ROD

If more than one connection appears in the table, simply replace the last letters of the reference with those of the connection required in order to obtain the correct mould.

For e.g.: If a vertical TT mould is needed for a 50 mm² cable to Ø14.3 mm earth rod, then the reference will be C50/T14/TT (instead of C50/T14/TV). The number of tablets and other accessories will remain the same.

6	Connection	Reference	Conductor 1	Conductor 2	Tab Ref.	Tab/Conn.	Clamp	Notes
TV		C35/T14/TV	35 mm ² cable	Ø14.3 mm earth rod	AT-020N	2	AT-049N	
		C35/T16/TV	35 mm ² cable	Ø15.9 mm earth rod	AT-020N	2	AT-049N	
		C50/T14/TV	50 mm ² cable	Ø14.3 mm earth rod	AT-020N	2	AT-049N	
		C50/T16/TV	50 mm ² cable	Ø15.9 mm earth rod	AT-020N	2	AT-049N	
		C50/T17/TV	50 mm ² cable	Ø17.2 mm earth rod	AT-020N	2.5	AT-049N	
TT		C50/T18/TV	50 mm ² cable	Ø18.3 mm earth rod	AT-020N	2.5	AT-049N	
		C50/T19/TV	50 mm ² cable	Ø19 mm earth rod	AT-020N	2.5	AT-049N	
		C70/T14/TV	70 mm ² cable	Ø14.3 mm earth rod	AT-020N	2.5	AT-049N	
		C70/T16/TV	70 mm ² cable	Ø15.9 mm earth rod	AT-020N	2.5	AT-049N	
		C70/T17/TV	70 mm ² cable	Ø17.2 mm earth rod	AT-020N	2.5	AT-049N	
		C70/T18/TV	70 mm ² cable	Ø18.3 mm earth rod	AT-020N	2.5	AT-049N	
		C70/T19/TV	70 mm ² cable	Ø19 mm earth rod	AT-020N	3	AT-049N	
		C95/T14/TV	95 mm ² cable	Ø14.3 mm earth rod	AT-020N	2.5	AT-049N	
		C95/T16/TV	95 mm ² cable	Ø15.9 mm earth rod	AT-020N	2.5	AT-049N	
		C95/T17/TV	95 mm ² cable	Ø17.2 mm earth rod	AT-020N	2.5	AT-049N	
		C95/T18/TV	95 mm ² cable	Ø18.3 mm earth rod	AT-020N	3	AT-049N	
		C95/T19/TV	95 mm ² cable	Ø19 mm earth rod	AT-020N	3	AT-049N	
		C120/T17/TV	120 mm ² cable	Ø17.2 mm earth rod	AT-020N	3	AT-049N	
		C120/T18/TV	120 mm ² cable	Ø18.3 mm earth rod	AT-020N	3	AT-049N	
		C120/T19/TV	120 mm ² cable	Ø19 mm earth rod	AT-020N	3.5	AT-049N	
		C120/T20/TV	120 mm ² cable	Ø20 mm earth rod	AT-020N	3.5	AT-049N	
		C120/T22/TV	120 mm ² cable	Ø22 mm earth rod	AT-020N	4	AT-049N	
		C120/T25/TV	120 mm ² cable	Ø25 mm earth rod	AT-020N	4.5	AT-049N	
		C150/T17/TV	150 mm ² cable	Ø17.2 mm earth rod	AT-020N	4	AT-049N	
		C150/T18/TV	150 mm ² cable	Ø18.3 mm earth rod	AT-020N	4	AT-049N	
		C150/T19/TV	150 mm ² cable	Ø19 mm earth rod	AT-020N	4.5	AT-049N	
		C150/T20/TV	150 mm ² cable	Ø20 mm earth rod	AT-020N	4.5	AT-049N	
		C150/T22/TV	150 mm ² cable	Ø22 mm earth rod	AT-020N	4.5	AT-049N	
C150/T25/TV	150 mm ² cable	Ø25 mm earth rod	AT-020N	5	AT-049N			
C185/T19/TV	185 mm ² cable	Ø19 mm earth rod	AT-021N	2	AT-050N			
C185/T20/TV	185 mm ² cable	Ø20 mm earth rod	AT-021N	2	AT-050N			
C185/T22/TV	185 mm ² cable	Ø22 mm earth rod	AT-021N	3	AT-050N			
C185/T25/TV	185 mm ² cable	Ø25 mm earth rod	AT-021N	3	AT-050N			
C240/T19/TV	240 mm ² cable	Ø19 mm earth rod	AT-021N	3	AT-050N			
C240/T20/TV	240 mm ² cable	Ø20 mm earth rod	AT-021N	3	AT-050N			
C240/T22/TV	240 mm ² cable	Ø22 mm earth rod	AT-021N	3	AT-050N			
C240/T25/TV	240 mm ² cable	Ø25 mm earth rod	AT-021N	3	AT-050N			

> REFERENCE SELECTION TABLE: SUITABLE MOULDS, TABLETS AND CLAMPS

7	Connection	Reference	Conductor 1	Conductor 2	Tab Ref.	Tab/Conn.	Clamp	Notes
	XO or VPH + AVX	C35/M/VPH + AV14	35 mm ² cable	Ø14.3 mm earth rod	AT-020N	2	AT-051N	Requires sealing paste AT-065N or AT-066N
		C35/M/VPH + AV16	35 mm ² cable	Ø15.9 mm earth rod	AT-020N	2	AT-051N	Requires sealing paste AT-065N or AT-066N
		C50/M/VPH + AV14	50 mm ² cable	Ø14.3 mm earth rod	AT-020N	2	AT-051N	Requires sealing paste AT-065N or AT-066N
		C50/M/VPH + AV16	50 mm ² cable	Ø15.9 mm earth rod	AT-020N	2	AT-051N	Requires sealing paste AT-065N or AT-066N
		C50/M/VPH + AV17	50 mm ² cable	Ø17.2 mm earth rod	AT-020N	2	AT-051N	Requires sealing paste AT-065N or AT-066N
		C50/M/VPH + AV18	50 mm ² cable	Ø18.3 mm earth rod	AT-020N	2	AT-051N	Requires sealing paste AT-065N or AT-066N
		C50/M/VPH + AV19	50 mm ² cable	Ø19 mm earth rod	AT-020N	2	AT-051N	Requires sealing paste AT-065N or AT-066N
		C70/M/VPH + AV14	70 mm ² cable	Ø14.3 mm earth rod	AT-020N	2	AT-051N	Requires sealing paste AT-065N or AT-066N
		C70/M/VPH + AV16	70 mm ² cable	Ø15.9 mm earth rod	AT-020N	2	AT-051N	Requires sealing paste AT-065N or AT-066N
		C70/M/VPH + AV17	70 mm ² cable	Ø17.2 mm earth rod	AT-020N	2	AT-051N	Requires sealing paste AT-065N or AT-066N
		C70/M/VPH + AV18	70 mm ² cable	Ø18.3 mm earth rod	AT-020N	2	AT-051N	Requires sealing paste AT-065N or AT-066N
		C70/M/VPH + AV19	70 mm ² cable	Ø19 mm earth rod	AT-020N	2	AT-051N	Requires sealing paste AT-065N or AT-066N
		C95/T14/XO	95 mm ² cable	Ø14.3 mm earth rod	AT-020N	2,5	AT-050N	Requires sealing paste AT-065N or AT-066N
		C95/T16/XO	95 mm ² cable	Ø15.9 mm earth rod	AT-020N	2,5	AT-050N	Requires sealing paste AT-065N or AT-066N
		C95/T17/XO	95 mm ² cable	Ø17.2 mm earth rod	AT-020N	3	AT-050N	Requires sealing paste AT-065N or AT-066N
		C95/T18/XO	95 mm ² cable	Ø18.3 mm earth rod	AT-020N	3,5	AT-050N	Requires sealing paste AT-065N or AT-066N
		C95/T19/XO	95 mm ² cable	Ø19 mm earth rod	AT-020N	4	AT-050N	Requires sealing paste AT-065N or AT-066N
		C120/T17/XO	120 mm ² cable	Ø17.2 mm earth rod	AT-020N	3	AT-050N	AT-065N or AT-066N Sealing paste and AT-091N jack tool
		C120/T18/XO	120 mm ² cable	Ø18.3 mm earth rod	AT-020N	4,5	AT-050N	AT-065N or AT-066N Sealing paste and AT-091N jack tool
		C120/T19/XO	120 mm ² cable	Ø19 mm earth rod	AT-020N	4,5	AT-050N	AT-065N or AT-066N Sealing paste and AT-091N jack tool
		C120/T20/XO	120 mm ² cable	Ø20 mm earth rod	AT-020N	4,5	AT-050N	AT-065N or AT-066N Sealing paste and AT-091N jack tool
		C120/T22/XO	120 mm ² cable	Ø22 mm earth rod	AT-020N	4,5	AT-050N	AT-065N or AT-066N Sealing paste and AT-091N jack tool
		C120/T25/XO	120 mm ² cable	Ø25 mm earth rod	AT-020N	5	AT-050N	AT-065N or AT-066N Sealing paste and AT-091N jack tool

8	Connection	Reference	Conductor 1	Conductor 2	Tab Ref.	Tab/Conn.	Clamp	Notes
	PO or VTA + AVX	C35/M/VTA + AV14	35 mm ² cable	Ø14.3 mm earth rod	AT-020N	2	AT-051N	Requires sealing paste AT-065N or AT-066N
		C35/M/VTA + AV16	35 mm ² cable	Ø15.9 mm earth rod	AT-020N	2	AT-051N	Requires sealing paste AT-065N or AT-066N
		C50/M/VTA + AV14	50 mm ² cable	Ø14.3 mm earth rod	AT-020N	2	AT-051N	Requires sealing paste AT-065N or AT-066N
		C50/M/VTA + AV16	50 mm ² cable	Ø15.9 mm earth rod	AT-020N	2	AT-051N	Requires sealing paste AT-065N or AT-066N
		C50/M/VTA + AV17	50 mm ² cable	Ø17.2 mm earth rod	AT-020N	2	AT-051N	Requires sealing paste AT-065N or AT-066N
		C50/M/VTA + AV18	50 mm ² cable	Ø18.3 mm earth rod	AT-020N	2	AT-051N	Requires sealing paste AT-065N or AT-066N
		C50/M/VTA + AV19	50 mm ² cable	Ø19 mm earth rod	AT-020N	2	AT-051N	Requires sealing paste AT-065N or AT-066N
		C70/M/VTA + AV14	70 mm ² cable	Ø14.3 mm earth rod	AT-020N	2	AT-051N	Requires sealing paste AT-065N or AT-066N
		C70/M/VTA + AV16	70 mm ² cable	Ø15.9 mm earth rod	AT-020N	2	AT-051N	Requires sealing paste AT-065N or AT-066N
		C70/M/VTA + AV17	70 mm ² cable	Ø17.2 mm earth rod	AT-020N	2	AT-051N	Requires sealing paste AT-065N or AT-066N
		C70/M/VTA + AV18	70 mm ² cable	Ø18.3 mm earth rod	AT-020N	2	AT-051N	Requires sealing paste AT-065N or AT-066N
		C70/M/VTA + AV19	70 mm ² cable	Ø19 mm earth rod	AT-020N	2	AT-051N	Requires sealing paste AT-065N or AT-066N
		C95/M/VTA + AV14	95 mm ² cable	Ø14.3 mm earth rod	AT-020N	2	AT-051N	Requires sealing paste AT-065N or AT-066N
		C95/M/VTA + AV16	95 mm ² cable	Ø15.9 mm earth rod	AT-020N	2	AT-051N	Requires sealing paste AT-065N or AT-066N
		C95/M/VTA + AV17	95 mm ² cable	Ø17.2 mm earth rod	AT-020N	2	AT-051N	Requires sealing paste AT-065N or AT-066N
		C95/M/VTA + AV18	95 mm ² cable	Ø18.3 mm earth rod	AT-020N	2	AT-051N	Requires sealing paste AT-065N or AT-066N
		C95/M/VTA + AV19	95 mm ² cable	Ø19 mm earth rod	AT-020N	2	AT-051N	Requires sealing paste AT-065N or AT-066N
		C120/T17/PO	120 mm ² cable	Ø17.2 mm earth rod	AT-020N	4,5	AT-050N	AT-065N or AT-066N Sealing paste and AT-091N jack tool
		C120/T18/PO	120 mm ² cable	Ø18.3 mm earth rod	AT-020N	4,5	AT-050N	AT-065N or AT-066N Sealing paste and AT-091N jack tool
		C120/T19/PO	120 mm ² cable	Ø19 mm earth rod	AT-020N	4,5	AT-050N	AT-065N or AT-066N Sealing paste and AT-091N jack tool
		C120/T20/PO	120 mm ² cable	Ø20 mm earth rod	AT-020N	4,5	AT-050N	AT-065N or AT-066N Sealing paste and AT-091N jack tool
		C120/T22/PO	120 mm ² cable	Ø22 mm earth rod	AT-020N	4,5	AT-050N	AT-065N or AT-066N Sealing paste and AT-091N jack tool
		C120/T25/PO	120 mm ² cable	Ø25 mm earth rod	AT-020N	5	AT-050N	AT-065N or AT-066N Sealing paste and AT-091N jack tool



> REFERENCE SELECTION TABLE: SUITABLE MOULDS, TABLETS AND CLAMPS

> CABLE/REBAR

If more than one connection appears in the table, simply replace the last letters of the reference with those of the connection required in order to obtain the correct mould.

For e.g.: If a PT mould for 35 mm² cable to Ø10 mm horizontal rebar is required, simply replace C35/V10/PV with C35/V10/PT. The number of tablets and other accessories will remain the same.

9	Connection	Reference	Conductor 1	Conductor 2	Tab Ref.	Tab/Conn.	Clamp	Notes
	PV	C35/V10/PV	35 mm ² cable	Ø10 mm rebar	AT-020N	2	AT-049N	Requires sealing paste AT-065N or AT-066N
		C35/V12/PV	35 mm ² cable	Ø12 mm rebar	AT-020N	2	AT-049N	Requires sealing paste AT-065N or AT-066N
		C35/V16/PV	35 mm ² cable	Ø16 mm rebar	AT-020N	1.5	AT-049N	Requires sealing paste AT-065N or AT-066N
		C35/V20/PV	35 mm ² cable	Ø20 mm rebar	AT-020N	1.5	AT-049N	Requires sealing paste AT-065N or AT-066N
		C35/V25/PV	35 mm ² cable	Ø25 mm rebar	AT-020N	1.5	AT-049N	Requires sealing paste AT-065N or AT-066N
	PT	C50/V10/PV	50 mm ² cable	Ø10 mm rebar	AT-020N	2	AT-049N	Requires sealing paste AT-065N or AT-066N
		C50/V12/PV	50 mm ² cable	Ø12 mm rebar	AT-020N	2.5	AT-049N	Requires sealing paste AT-065N or AT-066N
		C50/V16/PV	50 mm ² cable	Ø16 mm rebar	AT-020N	2	AT-049N	Requires sealing paste AT-065N or AT-066N
		C50/V20/PV	50 mm ² cable	Ø20 mm rebar	AT-020N	2	AT-049N	Requires sealing paste AT-065N or AT-066N
		C50/V25/PV	50 mm ² cable	Ø25 mm rebar	AT-020N	2	AT-049N	Requires sealing paste AT-065N or AT-066N
		C70/V10/PV	70 mm ² cable	Ø10 mm rebar	AT-020N	2	AT-049N	Requires sealing paste AT-065N or AT-066N
		C70/V12/PV	70 mm ² cable	Ø12 mm rebar	AT-020N	2.5	AT-049N	Requires sealing paste AT-065N or AT-066N
		C70/V16/PV	70 mm ² cable	Ø16 mm rebar	AT-020N	2	AT-049N	Requires sealing paste AT-065N or AT-066N
		C70/V20/PV	70 mm ² cable	Ø20 mm rebar	AT-020N	2	AT-049N	Requires sealing paste AT-065N or AT-066N
		C70/V25/PV	70 mm ² cable	Ø25 mm rebar	AT-020N	2	AT-049N	Requires sealing paste AT-065N or AT-066N
		C95/V10/PV	95 mm ² cable	Ø10 mm rebar	AT-020N	2.5	AT-049N	Requires sealing paste AT-065N or AT-066N
		C95/V12/PV	95 mm ² cable	Ø12 mm rebar	AT-020N	3	AT-049N	Requires sealing paste AT-065N or AT-066N
		C95/V16/PV	95 mm ² cable	Ø16 mm rebar	AT-020N	2	AT-049N	Requires sealing paste AT-065N or AT-066N
		C95/V20/PV	95 mm ² cable	Ø20 mm rebar	AT-020N	2	AT-049N	Requires sealing paste AT-065N or AT-066N
		C95/V25/PV	95 mm ² cable	Ø25 mm rebar	AT-020N	2	AT-049N	Requires sealing paste AT-065N or AT-066N

10	Connection	Reference	Conductor 1	Conductor 2	Tab Ref.	Tab/Conn.	Clamp	Notes
	XS	C35/V10/XS	35 mm ² cable	Ø10 mm rebar	AT-020N	2.5	AT-049N	Requires sealing paste AT-065N or AT-066N
		C35/V12/XS	35 mm ² cable	Ø12 mm rebar	AT-020N	3	AT-049N	Requires sealing paste AT-065N or AT-066N
		C35/V16/XS	35 mm ² cable	Ø16 mm rebar	AT-020N	3	AT-049N	Requires sealing paste AT-065N or AT-066N
		C35/V20/XS	35 mm ² cable	Ø20 mm rebar	AT-020N	3	AT-049N	Requires sealing paste AT-065N or AT-066N
		C35/V25/XS	35 mm ² cable	Ø25 mm rebar	AT-020N	4	AT-049N	Requires sealing paste AT-065N or AT-066N
		C50/V10/XS	50 mm ² cable	Ø10 mm rebar	AT-020N	3	AT-049N	Requires sealing paste AT-065N or AT-066N
		C50/V12/XS	50 mm ² cable	Ø12 mm rebar	AT-020N	3.5	AT-049N	Requires sealing paste AT-065N or AT-066N
		C50/V16/XS	50 mm ² cable	Ø16 mm rebar	AT-020N	3.5	AT-049N	Requires sealing paste AT-065N or AT-066N
		C50/V20/XS	50 mm ² cable	Ø20 mm rebar	AT-020N	3.5	AT-049N	Requires sealing paste AT-065N or AT-066N
		C50/V25/XS	50 mm ² cable	Ø25 mm rebar	AT-020N	4	AT-049N	Requires sealing paste AT-065N or AT-066N
		C70/V10/XS	70 mm ² cable	Ø10 mm rebar	AT-020N	3.5	AT-049N	Requires sealing paste AT-065N or AT-066N
		C70/V12/XS	70 mm ² cable	Ø12 mm rebar	AT-020N	4	AT-049N	Requires sealing paste AT-065N or AT-066N
		C70/V16/XS	70 mm ² cable	Ø16 mm rebar	AT-020N	4	AT-049N	Requires sealing paste AT-065N or AT-066N
		C70/V20/XS	70 mm ² cable	Ø20 mm rebar	AT-020N	4	AT-049N	Requires sealing paste AT-065N or AT-066N
		C70/V25/XS	70 mm ² cable	Ø25 mm rebar	AT-020N	4.5	AT-049N	Requires sealing paste AT-065N or AT-066N
		C95/V10/XS	95 mm ² cable	Ø10 mm rebar	AT-020N	3.5	AT-049N	Requires sealing paste AT-065N or AT-066N
		C95/V12/XS	95 mm ² cable	Ø12 mm rebar	AT-020N	4	AT-049N	Requires sealing paste AT-065N or AT-066N
		C95/V16/XS	95 mm ² cable	Ø16 mm rebar	AT-020N	4.5	AT-049N	Requires sealing paste AT-065N or AT-066N
		C95/V20/XS	95 mm ² cable	Ø20 mm rebar	AT-020N	4.5	AT-049N	Requires sealing paste AT-065N or AT-066N
		C95/V25/XS	95 mm ² cable	Ø25 mm rebar	AT-020N	5	AT-049N	Requires sealing paste AT-065N or AT-066N







> REFERENCE SELECTION TABLE: SUITABLE MOULDS, TABLETS AND CLAMPS

> CABLE/METAL SURFACE

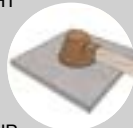
If more than one connection appears in the table, simply replace the last letters of the code with those of the connection required in order to obtain the correct mould.

For e.g.: If a HP mould for 35 mm² cable over horizontal surface is required, simply replace C35/M/HT with C35/M/HP. The number of tablets and other accessories will remain the same.

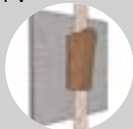
14	Connection	Reference	Conductor 1	Conductor 2	Tab Ref.	Tab/Conn.	Clamp	Notes
	HT	C35/M/HT	35 mm ² cable	Metal part	AT-020N	1.5	AT-049N	AT-058N clamp is recommended to ensure a secure connection
		C50/M/HT	50 mm ² cable	Metal part	AT-020N	2	AT-049N	AT-058N clamp is recommended to ensure a secure connection
		C70/M/HT	70 mm ² cable	Metal part	AT-020N	2	AT-049N	AT-058N clamp is recommended to ensure a secure connection
		C95/M/HT	95 mm ² cable	Metal part	AT-020N	2	AT-049N	AT-058N clamp is recommended to ensure a secure connection
	HP	C120/M/HT	120 mm ² cable	Metal part	AT-020N	2.5	AT-049N	AT-058N clamp is recommended to ensure a secure connection
		C150/M/HT	150 mm ² cable	Metal part	AT-020N	2.5	AT-049N	AT-058N clamp is recommended to ensure a secure connection
		C185/M/HT	185 mm ² cable	Metal part	AT-021N	2	AT-050N	AT-058N clamp is recommended to ensure a secure connection
		C240/M/HT	240 mm ² cable	Metal part	AT-021N	2	AT-050N	AT-058N clamp is recommended to ensure a secure connection





15	Connection	Reference	Conductor 1	Conductor 2	Tab Ref.	Tab/Conn.	Clamp	Notes
	VTB	C35/M/VTB	35 mm ² cable	Metal part	AT-020N	2	AT-051N	Requires sealing paste AT-065N or AT-066N
		C50/M/VTB	50 mm ² cable	Metal part	AT-020N	2	AT-051N	Requires sealing paste AT-065N or AT-066N
		C70/M/VTB	70 mm ² cable	Metal part	AT-020N	2	AT-051N	Requires sealing paste AT-065N or AT-066N
		C95/M/VTB	95 mm ² cable	Metal part	AT-020N	2.5	AT-051N	Requires sealing paste AT-065N or AT-066N
		C120/M/VTB	120 mm ² cable	Metal part	AT-020N	2.5	AT-051N	Requires sealing paste AT-065N or AT-066N
		C150/M/VTB	150 mm ² cable	Metal part	AT-020N	2.5	AT-051N	Requires sealing paste AT-065N or AT-066N
	VPV	C185/M/VTB	185 mm ² cable	Metal part	AT-021N	2	AT-050N	Requires sealing paste AT-065N or AT-066N
		C240/M/VTB	240 mm ² cable	Metal part	AT-021N	2	AT-050N	Requires sealing paste AT-065N or AT-066N
	VTH							
	VPH							

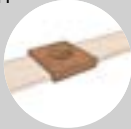

> REFERENCE SELECTION TABLE: SUITABLE MOULDS, TABLETS AND CLAMPS

> TAPE/TAPE

If more than one connection appears in the table, simply replace the last letters of the reference with those of the connection required in order to obtain the correct mould.

For e.g.: If a LH mould for a horizontal tape to tape bond is required, simply replace P302/P302/LV with P302/P302/LH. The number of tablets will remain the same.

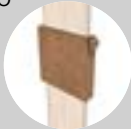

16	Connection	Reference	Conductor 1	Conductor 2	Tab Ref.	Tab/Conn.	Clamp	Notes
	LV	P302/P302/LV	Tape 30 x 2 mm	Tape 30 x 2 mm	AT-020N	2	AT-049N	
		P253/P253/LV	Tape 25 x 3 mm	Tape 25 x 3 mm	AT-020N	1.5	AT-049N	
		P305/P305/LV	Tape 30 x 5 mm	Tape 30 x 5 mm	AT-020N	2.5	AT-049N	
		P405/P405/LV	Tape 40 x 5 mm	Tape 40 x 5 mm	AT-020N	3.5	AT-049N	
		P605/P605/LV	Tape 60 x 5 mm	Tape 60 x 5 mm	AT-021N	3	AT-050N	
	LH							
	TH							
	TV							
	XS							

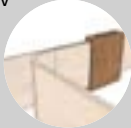
17	Connection	Reference	Conductor 1	Conductor 2	Tab Ref.	Tab/Conn.	Clamp	Notes
	LO	P302/P302/LO	Tape 30 x 2 mm	Tape 30 x 2 mm	AT-020N	3	AT-050N	
		P253/P253/LO	Tape 25 x 3 mm	Tape 25 x 3 mm	AT-020N	3	AT-050N	
		P305/P305/LO	Tape 30 x 5 mm	Tape 30 x 5 mm	AT-020N	4.5	AT-050N	
		P405/P405/LO	Tape 40 x 5 mm	Tape 40 x 5 mm	AT-020N	4.5	AT-050N	
		P605/P605/LO	Tape 60 x 5 mm	Tape 60 x 5 mm	AT-020N	5	AT-050N	
	TO							

18	Connection	Reference	Conductor 1	Conductor 2	Tab Ref.	Tab/Conn.	Clamp	Notes
	PV	P302/P302/PV	Tape 30 x 2 mm	Tape 30 x 2 mm	AT-020N	2.5	AT-049N	
		P253/P253/PV	Tape 25 x 3 mm	Tape 25 x 3 mm	AT-020N	2	AT-049N	
		P305/P305/PV	Tape 30 x 5 mm	Tape 30 x 5 mm	AT-020N	3	AT-049N	
		P405/P405/PV	Tape 40 x 5 mm	Tape 40 x 5 mm	AT-020N	5	AT-049N	
		P605/P605/PV	Tape 60 x 5 mm	Tape 60 x 5 mm	AT-021N	4	AT-050N	

**> REFERENCE SELECTION TABLE: SUITABLE MOULDS, TABLETS AND CLAMPS****> CABLE/TAPE**

If more than one connection appears in the table, simply replace the last letters of the reference with those of the connection required in order to obtain the correct mould. For e.g.: If a LH mould for 30x2 mm tape to 50 mm² cable is required, simply replace C50/P302/TH with C50/P302/LH. The number of tablets will remain the same.



19	Connection	Reference	Conductor 1	Conductor 2	Tab Ref.	Tab/Conn.	Clamp	Notes
	TH	C35/P302/TH	35 mm ² cable	Tape 30 x 2 mm	AT-020N	1.5	AT-049N	
		C50/P302/TH	50 mm ² cable	Tape 30 x 2 mm	AT-020N	2	AT-049N	
		C70/P302/TH	70 mm ² cable	Tape 30 x 2 mm	AT-020N	2	AT-049N	
		C35/P253/TH	35 mm ² cable	Tape 25 x 3 mm	AT-020N	1.5	AT-049N	
		C50/P253/TH	50 mm ² cable	Tape 25 x 3 mm	AT-020N	2	AT-049N	
	LH	C70/P253/TH	70 mm ² cable	Tape 25 x 3 mm	AT-020N	2	AT-049N	
		C70/P305/TH	70 mm ² cable	Tape 30 x 5 mm	AT-020N	3	AT-049N	
		C95/P305/TH	95 mm ² cable	Tape 30 x 5 mm	AT-020N	3	AT-049N	
		C120/P305/TH	120 mm ² cable	Tape 30 x 5 mm	AT-020N	4,5	AT-049N	
		C150/P305/TH	150 mm ² cable	Tape 30 x 5 mm	AT-020N	45	AT-049N	
		C150/P605/TH	150 mm ² cable	Tape 60 x 5 mm	AT-020N	5	AT-049N	
		C185/P605/TH	240 mm ² cable	Tape 60 x 5 mm	AT-021N	3	AT-050N	
		C240/P605/TH	240 mm ² cable	Tape 60 x 5 mm	AT-021N	4	AT-050N	

20	Connection	Reference	Conductor 1	Conductor 2	Tab Ref.	Tab/Conn.	Clamp	Notes
	TH	P302/C35/TH	35 mm ² cable	Tape 30 x 2 mm	AT-020N	1	AT-049N	
		P302/C50/TH	50 mm ² cable	Tape 30 x 2 mm	AT-020N	2	AT-049N	
		P302/C70/TH	70 mm ² cable	Tape 30 x 2 mm	AT-020N	2	AT-049N	
		P253/C35/TH	35 mm ² cable	Tape 25 x 3 mm	AT-020N	1.5	AT-049N	
		P302/C35/TH	35 mm ² cable	Tape 30 x 2 mm	AT-020N	1	AT-049N	
		P302/C50/TH	50 mm ² cable	Tape 30 x 2 mm	AT-020N	2	AT-049N	
		P302/C70/TH	70 mm ² cable	Tape 30 x 2 mm	AT-020N	2	AT-049N	
		P253/C35/TH	35 mm ² cable	Tape 25 x 3 mm	AT-020N	1.5	AT-049N	
		P253/C50/TH	50 mm ² cable	Tape 25 x 3 mm	AT-020N	2	AT-049N	
		P253/C70/TH	70 mm ² cable	Tape 25 x 3 mm	AT-020N	2	AT-049N	
		P305/C70/TH	70 mm ² cable	Tape 30 x 5 mm	AT-020N	2	AT-049N	
		P305/C95/TH	95 mm ² cable	Tape 30 x 5 mm	AT-020N	2.5	AT-049N	
		P305/C120/TH	120 mm ² cable	Tape 30 x 5 mm	AT-020N	2.5	AT-049N	
		P305/C150/TH	150 mm ² cable	Tape 30 x 5 mm	AT-020N	2.5	AT-049N	
		P605/C150/TH	150 mm ² cable	Tape 60 x 5 mm	AT-020N	5	AT-049N	
		P605/C185/TH	185mm ² cable	Tape 60 x 5 mm	AT-021N	2	AT-050N	
P605/C240/TH	240 mm ² cable	Tape 60 x 5 mm	AT-021N	3	AT-050N			

> TAPE/EARTH ROD

21	Connection	Reference	Conductor 1	Conductor 2	Tab Ref.	Tab/Conn.	Clamp	Notes
	TV	P302/T14/TV	Tape 30 x 2 mm	Ø14.3 mm earth rod	AT-020N	3	AT-049N	
		P302/T16TV	Tape 30 x 2 mm	Ø15.9 mm earth rod	AT-020N	3	AT-049N	
		P302/T18/TV	Tape 30 x 2 mm	Ø18.3 mm earth rod	AT-020N	3.5	AT-049N	
		P253/T14/TV	Tape 25 x 3 mm	Ø14.3 mm earth rod	AT-020N	2.5	AT-049N	
		P253/T16/TV	Tape 25 x 3 mm	Ø15.9 mm earth rod	AT-020N	3	AT-049N	
		P253/T18/TV	Tape 25 x 3 mm	Ø18.3 mm earth rod	AT-020N	3	AT-049N	

> OTHERS

22	Connection	Reference	Conductor 1	Conductor 2	Tab Ref.	Tab/Conn.	Clamp	Notes
	HT	C35/B/HT	35 mm ² cable	Metal part	AT-020N	1.5	AT-049N	Consult before placing an order
		C50/B/HT	50 mm ² cable	Metal part	AT-020N	2	AT-049N	Consult before placing an order
		C70/B/HT	70 mm ² cable	Metal part	AT-020N	2	AT-049N	Consult before placing an order
		C95/B/HT	95 mm ² cable	Metal part	AT-020N	2.5	AT-049N	Consult before placing an order
		C120/B/HT	120 mm ² cable	Metal part	AT-020N	2.5	AT-049N	Consult before placing an order
	VTO	C150/B/HT	150 mm ² cable	Metal part	AT-020N	3	AT-049N	Consult before placing an order
		C185/B/HT	185 mm ² cable	Metal part	AT-021N	NA	AT-050N	Consult before placing an order
		C240/B/HT	240 mm ² cable	Metal part	AT-021N	NA	AT-050N	Consult before placing an order

> REFERENCE SELECTION TABLE: SUITABLE MOULDS, TABLETS AND CLAMPS

> APLIWELD® Secure+ WELDING FOR TRACKS

Cable to train railway welding operates in the exact same way as the others, although the rail to be used in each case must be specified. If the connection you need is not mentioned, please contact us.

23	Connection	Reference	Conductor 1	Conductor 2	Tab Ref.	Tab/Conn.	Clamp	Rail sleeve
	CR	C35/CR	35 mm ² cable	Rail head	2	AT-020N	AT-056N	AT-SC35
	C50/CR	50 mm ² cable	Rail head	2	AT-020N	AT-056N	AT-SC50	
	C70/CR	70 mm ² cable	Rail head	2	AT-020N	AT-056N	AT-SC70	
	C95/CR	95 mm ² cable	Rail head	2.5	AT-020N	AT-056N	AT-SC95	
	C120/CR	120 mm ² cable	Rail head	2.5	AT-020N	AT-056N	AT-SC120	
	C150/CR	150 mm ² cable	Rail head	3	AT-020N	AT-056N	AT-SC150	

24	Connection	Reference	Conductor 1	Conductor 2	Tab Ref.	Tab/Conn.	Clamp	Remarks
	CR2	C35/CR2	35 mm ² cable	Rail head	2 + 2	AT-020N	AT-057N	Clamp comprises 2 AT-056N
	C50/CR2	50 mm ² cable	Rail head	2 + 2	AT-020N	AT-057N	AT-057N	Clamp can also be 2 AT-056N
	C70/CR2	70 mm ² cable	Rail head	2 + 2	AT-020N	AT-057N	AT-057N	Clamp comprises 2 AT-056N
	C95/CR2	95 mm ² cable	Rail head	2.5 + 2.5	AT-020N	AT-057N	AT-057N	Clamp comprises 2 AT-056N
	C120/CR2	120 mm ² cable	Rail head	2.5 + 2.5	AT-020N	AT-057N	AT-057N	Clamp comprises 2 AT-056N
	C150/CR2	150 mm ² cable	Rail head	3 + 3	AT-020N	AT-057N	AT-057N	Clamp comprises 2 AT-056N

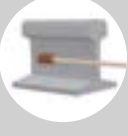
25	Connection	Reference	Conductor 1	Conductor 2	Tab Ref.	Tab/Conn.	Clamp	Rail sleeve
	AR	C35/AR	35 mm ² cable	Rail web	2	AT-020N	AT-054N	AT-SC35
	C50/AR	50 mm ² cable	Rail web	2	AT-020N	AT-054N	AT-054N	AT-S50
	C70/AR	70 mm ² cable	Rail web	2	AT-020N	AT-054N	AT-054N	AT-SC70
	C95/AR	95 mm ² cable	Rail web	2.5	AT-020N	AT-054N	AT-054N	AT-SC95
	C120/AR	120 mm ² cable	Rail web	2.5	AT-020N	AT-054N	AT-054N	AT-SC120
	C150/AR	150 mm ² cable	Rail web	3	AT-020N	AT-054N	AT-054N	AT-SC150

26	Connection	Reference	Conductor 1	Conductor 2	Tab Ref.	Tab/Conn.	Clamp	Railsleeve
	PAR	C35/PAR	35 mm ² cable	Rail web/foot	2	AT-020N	AT-054N	AT-SC35
	C50/PAR	50 mm ² cable	Rail web/foot	2	AT-020N	AT-054N	AT-054N	AT-SC50
	C70/PAR	70 mm ² cable	Rail web/foot	2	AT-020N	AT-054N	AT-054N	AT-SC70
	C95/PAR	95 mm ² cable	Rail web/foot	2.5	AT-020N	AT-054N	AT-054N	AT-SC95
	C120/PAR	120 mm ² cable	Rail web/foot	2.5	AT-020N	AT-054N	AT-054N	AT-SC120
	C150/PAR	150 mm ² cable	Rail web/foot	3	AT-020N	AT-054N	AT-054N	AT-SC150

27	Connection	Reference	Conductor 1	Conductor 2	Tab Ref.	Tab/Conn.	Clamp	Remarks
	BR	C35/BR	35 mm ² cable	Rail foot	2	AT-020N	N/A	Single-use mould
	C50/BR	50 mm ² cable	Rail foot	2	AT-020N	N/A	N/A	Single-use mould
	C70/BR	70 mm ² cable	Rail foot	2	AT-020N	N/A	N/A	Single-use mould
	C95/BR	95 mm ² cable	Rail foot	2.5	AT-020N	N/A	N/A	Single-use mould
	C120/BR	120 mm ² cable	Rail foot	2.5	AT-020N	N/A	N/A	Single-use mould
	C150/BR	150 mm ² cable	Rail foot	3	AT-020N	N/A	N/A	Single-use mould

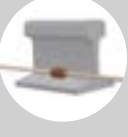
28	Connection	Reference	Conductor 1	Conductor 2	Tab Ref.	Tab/Conn.	Clamp	Remarks
	BRP	C35/BRP	35 mm ² cable	Rail foot	2	AT-020N	N/A	Single-use mould
	C50/BRP	50 mm ² cable	Rail foot	2	AT-020N	N/A	N/A	Single-use mould
	C70/BRP	70 mm ² cable	Rail foot	2	AT-020N	N/A	N/A	Single-use mould
	C95/BRP	95 mm ² cable	Rail foot	2.5	AT-020N	N/A	N/A	Single-use mould
	C120/BRP	120 mm ² cable	Rail foot	2.5	AT-020N	N/A	N/A	Single-use mould
	C150/BRP	150 mm ² cable	Rail foot	3,5	AT-020N	N/A	N/A	Single-use mould

It is recommended to use AT-065N or AT-066N sealing paste for all the connections



> MULTIPLE MOULD SELECTION GUIDE

The multiple mould is normally supplied in a case with the general reference **MM-CTX** (*), where X is the diameter of the earth rod required. All other references related to the multiple mould, such as the individual parts in the case and the basic kits, are also listed.

29	Reference	Description	Notes
	MM-CT14	Multiple mould case for Ø14.3 mm earth rod	See description in table 30
	MM-CT16	Multiple mould case for Ø16 mm earth rod	See description in table 30
	MM-CT17	Multiple mould case for Ø17.2 mm earth rod	See description in table 30
	MM-CT18	Multiple mould case for Ø18.3 mm earth rod	See description in table 30
	MM-CT19	Multiple mould case for Ø19 mm earth rod	See description in table 30
	MM-BT14	Basic multiple mould kit for Ø14.3 mm earth rod	Includes crucible, clamp and lower parts
	MM-BT16	Basic multiple mould kit for Ø16 mm earth rod	Includes crucible, clamp and lower parts
	MM-BT17	Basic multiple mould kit for Ø17.2 mm earth rod	Includes crucible, clamp and lower parts
	MM-BT18	Basic multiple mould kit for Ø18.3 mm earth rod	Includes crucible, clamp and lower parts
	MM-BT19	Basic multiple mould kit for Ø19 mm earth rod	Includes crucible, clamp and lower parts
	MM-053N	Multiple mould clamp	Included in all MM-CTX and MM-BTX kits (*)
	MM-CS	Cavity sealant (60 units)	2 included in all MM-CTX
	MM-PH	Lower part for cable and tape welding	Included in all MM-CTX and MM-BTX
	MM-PT14	Lower part for Ø14.3 mm earth rod	Included in MM-CT14 and MM-BT14
	MM-PT16	Lower part for Ø16 mm earth rod	Included in MM-CT16 and MM-BT16
	MM-PT17	Lower part for Ø17.2 mm earth rod	Included in MM-CT17 and MM-BT17
	MM-PT18	Lower part for Ø18.3 mm earth rod	Included in MM-CT18 and MM-BT18
	MM-PT19	Lower part for Ø19 mm earth rod	Included in MM-CT19 and MM-BT19
	MM-T	Multiple mould crucible	Included in all MM-CTX and MM-BTX
	AT-082N	Vertical stand pliers	Included in all MM-CTX

(*) X = 14, 16, 17, 18 and 19

References included in every MM-CTX case

30	Code	Description	Units
	MM-PTX	Lower part for earth rod with X diameter (*)	1
	MM-053N	Multiple mould clamp	1
	MM-T	Multiple mould crucible	1
	MM-PH	Lower part for cable and tape welding	1
	MM-CS	Cavity sealant (60 units)	2
	AT-080N	Multiple mould case	1
	AT-060N	Spark lighter (for powder starter)	1
	AT-061N	Conductor cleaning brush	1
	AT-062N	Crucible and electronic starter cavity cleaning brush	1
	AT-063N	Slag removal spade	1
	AT-064N	Welding cavity cleaning brush	1
	AT-065N	Sealing paste to prevent material leaking	1
	AT-073N	Safety gloves	1
	AT-082N	Vertical stand pliers for earth rod welding	1

(*) X = 14, 16, 17, 18 and 19

All parts may be purchased individually or as spare parts.

The following table describes the appropriate number of tablets and cavity sealants for any connection, as well as how to use them:

31	Conductor 1		Conductor 2		Connection	Tablets	SC	SC/Layers
Cable	Up to 70 mm ²	Cable	Up to 70 mm ²	Horizontal T	2	2	1+1	
Cable	95 mm ²	Cable	Up to 95 mm ²	Horizontal T	2.5	4	2+2	
Cable	Up to 50 mm ²	Cable	Up to 50 mm ²	Cross	2	3	1+1+1	
Cable	70 mm ²	Cable	70 mm ²	Cross	2.5	4	1+2+1	
Cable	95 mm ²	Cable	Up to 95 mm ²	Cross	2.5	6	2+2+2	
Cable	Up to 70 mm ²	Øearth rod	Any	Vertical T	2	2	1+1	
Cable	95 mm ²	Øearth rod	Any	Vertical T	2.5	4	2+2	
Tape	Any	Tape	Any	T/cross	2	3	1+1+1	
Tape	Any	Øearth rod	Any	T	2	2	1+1	

> SC = Cavity Sealants.

> SC/layer: Number of sealants between layers of conductors.

> Besides those described, linear welds are possible for all combinations.

They require 2 tablets with the exception of 95 mm² cable which requires 2.5 tablets.

> The following equivalence can be applied for round bar up to 12 mm:

C70 = V10 and C95 = V12.

> For cable to tape bonds, the tape corresponds to cables of up to 50 mm².

> Parallel connections are possible for cables of up to 50 mm². They all require 2.5 tablets with 1+2+2 SC.

> For any other bond required but not described, please get in touch with us.

> REFERENCE LIST APLIWELD® SECURE+

APLIWELD®-T tablet references

32	Reference	Description	Notes
	AT-020N	20 standard APLIWELD® tablets	
	AT-021N	20 large format APLIWELD® tablets	

References for using **APLIWELD®-E** electronic ignition

33	Reference	Description	Notes
	AT-100N	Electronic starting device	
	AT-010N	10 electronic starters + 10 contention discs	
	AT-069N	Basic accessories kit APLIWELD®-E	
	AT-096N	Electronic ignition device (without accessories)	Included in AT-100N
	AT-098N	Standard cable for the ignition device (2m)	Included in AT-100N
	AT-099N	5 spare clamps for electronic starter connector	Included in AT-100N
	AT-101N	Battery charger for the electronic ignition device	Included in AT-100N

References for traditional ignition

34	Reference	Description	Notes
	AT-012N	10 units of starting powder + 10 contention discs	
	AT-068N	APLIWELD® basic accessories kit with spark lighter	

References for clamps and clamp accessories

35	Reference	Description	Reference	Description
	AT-049N	General clamp type S	AT-059N	Cable-holder clamp
	AT-050N	General clamp type G	AT-056N	Cable clamp/Rail head
	AT-051N	Clamp for welding to vertical surface or rebars	AT-057N	Cable clamp/Rail head
	AT-058N	Clamp accessory for welding to horizontal surfaces	AT-054N	Cable clamp/Rail web

Other accessories and tools

36	Reference	Description	Notes
	AT-060N	Spark lighter	Included in AT-068N
	AT-061N	Conductor cleaning brush	Included in AT-069N and AT-068N
	AT-062N	Crucible and electronic starter cavity cleaning brush	Included in AT-069N and AT-068N
	AT-063N	Slag removal spade	Included in AT-069N and AT-068N
	AT-064N	Welding cavity cleaning brush	Included in AT-069N and AT-068N
	AT-065N	Sealing paste (0.45 kg)	Included in AT-069N and AT-068N
	AT-066N	Sealing paste (0.9 kg)	
	AT-070N	Spark lighter spare flint	
	AT-071N	Sealing paste (2.25 kg)	
	AT-072N	25 cable wrap sleeves (0.3 mm)	
	AT-072NCXX	Adapters to XX cable	XX can be 50, 70, 120...
	AT-073N	Safety gloves	Included in AT-069N and AT-068N
	AT-074N	Spark lighter extension	
	AT-075N	Blow torch for pre-heating moulds	
	AT-076N	Spare multigas cartridge for the blow torch	
	AT-077N	Safety goggles	
	AT-081N	Ceramic tray	
	AT-083N	Ceramic blanket	
	AT-092N	Double brush for conductor cleaning	
	AT-093N	Double conductor brush replacements	
	AT-094N	Surface rasp + replacement	